

DIAPHRAGM PRESSURE GAUGE

DMG SERIES

Technical Data

Mounting Style: Horizontal diaphragm

Measuring Range: Positive pressure, Vacuum (Negative pressure), and compound pressure available

Indicating Case Size: 100mm (4") or 160mm (6")

Case Housing Protection: IP65, liquid filled available

Accuracy Class: $\pm 1.6\%$ full scale, $\pm 1.0\%$ on request

Operating Pressure Limited: Steady pressure—full scale value

Fluctuating (pulsating)—90% of full scale value

Pressure ≥ 40 mbar for membrane—SS316

Pressure ≥ 40 mbar for case filled gauge

Over Pressure Limited: 5 x full scale value, but up limited to 40bar

Operating Temperature Limited: -20°C ~ 0 ~ $+100^{\circ}\text{C}$, w/cooling element, or capillary up to 350°C

Process Connection: $\frac{1}{2}$ "NPT, $\frac{1}{2}$ "BSP and M20 x 1.5 available; option on request

Material: Case Bezel Ring (Bayonet type)—SS304 or SS316

Indicating Dial—Aluminum Alloy (white painting black letters)

Movement—Stainless Steel or Brass

Pointer—Aluminum Alloy (black painting); Option: micro adjustable version on request

Window—Safety Glass

Blow-Out (vent)—Rubber (at the top of case)

Measuring Flange—Upper & Lower Flange—SS316

Diaphragm Membrane— ≤ 0.25 bar—SS316Ti; > 0.25 bar—Duratherm (Nicro-Alloy)

Gasket—FPM(Viton) or PTFE

Measuring Element—Diaphragm Flange Size: $\varnothing 100$ mm(4") or $\varnothing 160$ mm(6")

Wetted Parts—SS316



Principle

DMG Series diaphragm pressure gauge combine with main component a diaphragm membrane, transmission rod and gear element as drawing.

When pressure input pressure chamber to up the diaphragm membrane, then transmission rod follow up directly push gear element to indicating pressure range by pointer (No need filled oil inside diaphragm) as over view section drawing.

Pressure scale spacing and scale numbers according to per EN837-3.

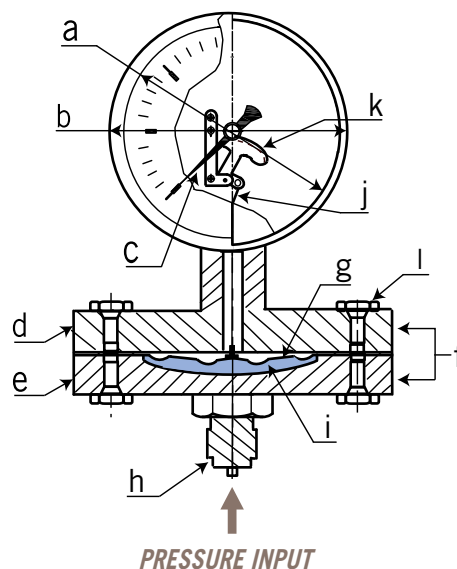

Parts List

Item	Description of Parts
a	Dial
b	Indicating case
c	Pointer
d	Upper flange (measuring flange)
e	Lower flange (measuring flange)
f	Measuring flange
g	Diaphragm membrane
h	Process connection
i	Pressure chamber
j	Transmission rod
k	Gear element
l	Fix bolt

Range Selection Table

1. unit: mbar

Code	Range	Subdivision	Code	Range	Subdivision	Code	Range	Subdivision
1M	0~10	0.2	6M	0~100	2	11M	-6~+4	0.2
2M	0~16	0.5	7M	0~160	5	12M	-6~+10	0.5
3M	0~25	0.5	8M	0~250	5	13M	-10~+6	0.5
4M	0~40	1	9M	0~400	10	14M	-10~+15	0.5
5M	0~60	1	10M	-4~+6	0.2	15M	-15~+10	0.5
Code	Range	Subdivision	Code	Range	Subdivision	Code	Range	Subdivision
16M	-15~+25	1	21M	-40~+20	1	26M	-100~+60	5
17M	-20~+20	1	22M	-40~+60	2	27M	-100~+50	5
18M	-25~+15	1	23M	-50~+50	2	28M	-150~+100	5
19M	-20~+40	1	24M	-60~+40	2	29M	-150~+250	10
20M	-30~+30	1	25M	-60~+100	5	30M	-200~+200	10
Code	Range	Subdivision	Code	Range	Subdivision	Code	Range	Subdivision
31M	-250~+150	10	36M	-60~+0	1	41M	-1200~+0	20
32M	-10~+0	0.2	37M	-100~+0	2			
33M	-16~+0	0.5	38M	-160~+0	5			
34M	-25~+0	0.5	39M	-250~+0	5			
35M	-40~+0	1	40M	-400~+0	10			

2. unit: bar

Code	Range	Subdivision	Code	Range	Subdivision	Code	Range	Subdivision
1B	0~0.4	0.01	6B	0~4	0.1	11B	-1~+0.6	0.05
2B	0~0.6	0.01	7B	0~6	0.1	12B	-1~+1.5	0.05
3B	0~1.0	0.02	8B	0~10	0.2	13B	-1~+3	0.1
4B	0~1.6	0.05	9B	0~16	0.5	14B	-1~+5	0.1
5B	0~2.5	0.05	10B	0~25	0.5	15B	-1~+9	0.2
Code	Range	Subdivision	Code	Range	Subdivision	Code	Range	Subdivision
16B	-1~+15	0.5						
17B	-0.4~+0	0.01						
18B	-0.6~+0	0.01						
19B	-1~+0	0.02						

3. unit: psi

Code	Range	Subdivision	Code	Range	Subdivision	Code	Range	Subdivision
1P	0~10	0.1	6P	0~160	2			
2P	0~15	0.25	7P	0~200	2			
3P	0~30	0.5	8P	0~300	5			
4P	0~60	1	9P	0~400	5			
5P	0~100	1						

NOTE.

1bar=1000 mbar

Special scale range unit: kg/cm², MPa, KPa, Pa, mmWs(mmH₂O), mmHg., etc are available on request.

Process Connection: Thread Type

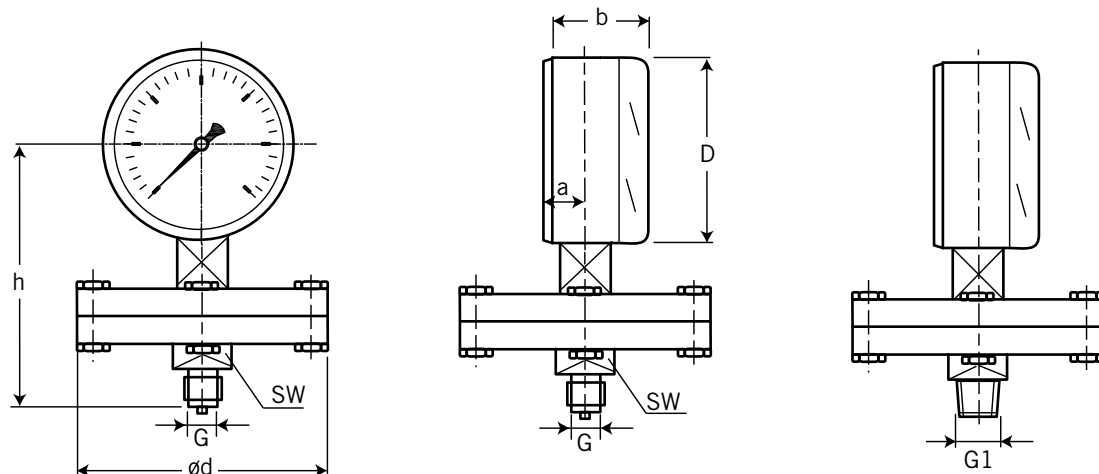

unit=mm

Case Size øD	Pressure Range Bar	Measuring Flange ød	Dimension					Weight (kg)
			a	b	h±2	G	G1	
100 / 4"	≤ 0.4	ø160	18	48	130	G½A	½"NPT	3.7
160 / 6"			18	50	160	G½A	½"NPT	3.9
100 / 4"	> 0.4	ø100	18	48	130	G½A	½"NPT	2.1
160 / 6"			18	50	160	G½A	½"NPT	2.3

Process Connection: Flange Type

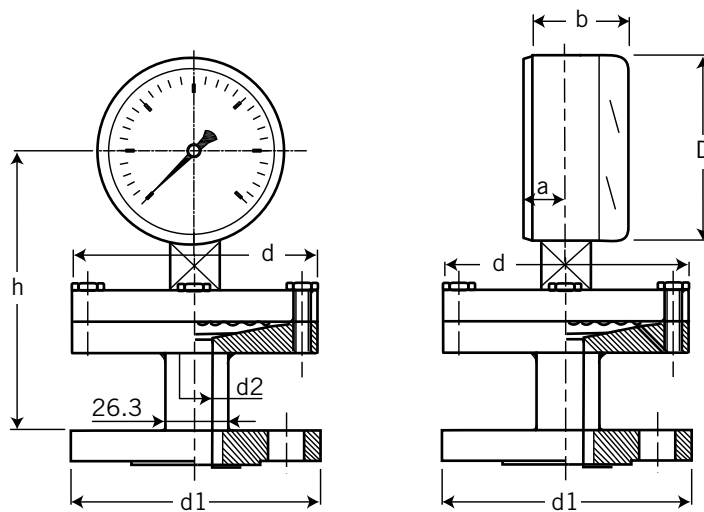

unit=mm

Case Size øD	Pressure Range Bar	Measuring Flange ød	Dimension			
			a	b	h±2	d2
100 / 4"	≤ 0.4	ø160	18	48	143.7	21.0±1
160 / 6"			18	50	143.7	21.0±1
100 / 4"	> 0.4	ø100	18	48	143.7	21.0±1
160 / 6"			18	50	143.7	21.0±1

*Please note d1 dimension is according to the flange rating and size.

Ordering Information

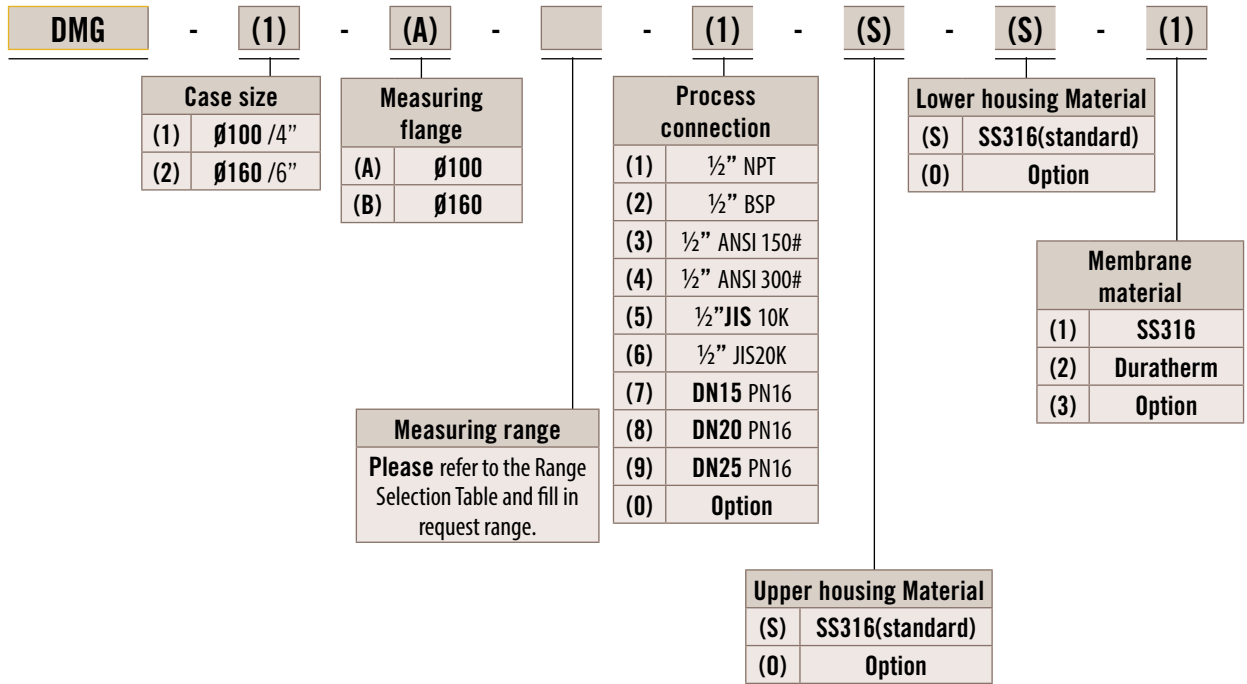

Расход

Уровень

Температура

Давление

Клапаны