

Differential Pressure Gauges

Model 700.01, With Magnetic Piston

Model 700.02, With Magnetic Piston and Separation Diaphragm

WIKA Data Sheet PM 07.14

Applications

- Filter plants
- Pump monitoring
- Cooling circuits
- Pipeline systems

Special Features

- Differential pressure measuring ranges
Model 700.01: from 0 ... 400 mbar to 0 ... 10 bar
Model 700.02: from 0 ... 160 mbar to 0 ... 2.5 bar
- Sturdy and compact system case made of stainless steel
- High working pressures (static pressures), optionally 100, 250 or 400 bar (Model 700.02 to 100 bar max.)
- Overpressure safe either side to maximum working pressure (exception for Model 700.02: see table page 2)
- System and/or case of indication may be changed locally
- Reed contacts may also be adjusted and retrofitted locally

Description

Model 700.01 is particularly intended for the monitoring of differential pressures even in the case of high working pressures in gas and air preparation and supply systems.

Model 700.02, the version with a separation diaphragm, is suitable for liquid media and therefore also for water treatment and supply systems.

This piston-type differential pressure gauge offers special advantages due to its compact modular design. For instance an on-the-spot replacement of measuring system and case of indication is possible in retrospect and the Reed contacts can also be retrofitted and adjusted locally.

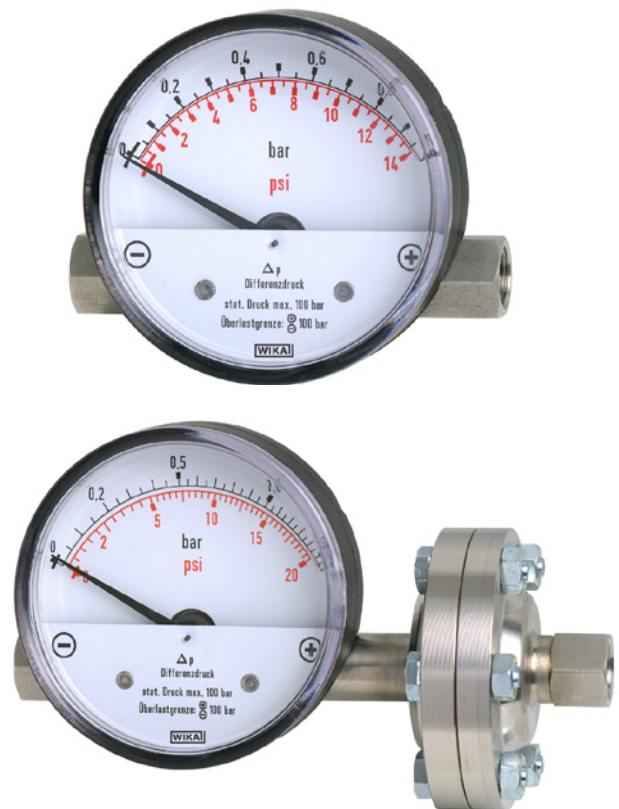

Fig. top: Model 700.01

Fig. bottom: Model 700.02, with separation diaphragm

A front surface mounting flange may be retrofitted on model 700.01.

Although these models have a high overload capacity either side up to the maximum working pressure, the weight of the standard versions, i.e. approx. 220 g in the case of model 700.01 and approx. 500 g in the case of model 700.02, is extremely low. Therefore, these gauges provide an economical and flexible solution to your measuring task.

This compact design with a measuring system of stainless steel enables an optimal price/performance ratio.

Illustration of operating principle

Model 700.01

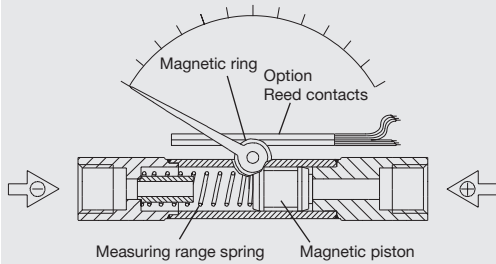

Model 700.02

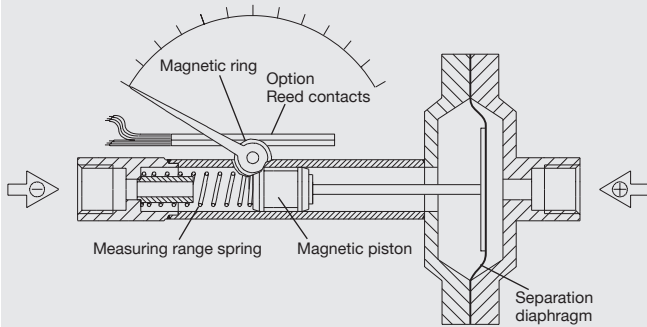

Design and operating principle

Pressure p_1 and p_2 are given in the \oplus and \ominus measuring medium chambers separated by magnetic piston under pressure or magnetic piston and separation diaphragm for Model 700.02.

The difference in pressure causes axial movement (measuring travel) of the piston supported by a measuring range spring.

A magnetic ring mounted on the instrument pointer follows the magnet's movement in the piston so that each piston position is appropriated to a defined pointer position.

This design ensures complete mechanical separation of the measuring system and the case and eliminates external leakage.

The stream of volume from the \oplus measuring chamber to the \ominus measuring chamber is minimised by the constructive design and will not interfere with the process (only for Model 700.01).

For applications where liquids or dirty and heavily contaminated media are to be measured the version with a separation diaphragm Model 700.02, is suitable (no volume flow from \oplus and \ominus media chamber).

Installation

Pressure entries identified \oplus and \ominus ,

\oplus high pressure, \ominus low pressure

Mounting by means of

- rigid tailpipes,
- panel mounting (optional extra) or
- device for surface mounting (optional extra)

Specifications	Model 700.01	Model 700.02
Nominal size	80 mm	
Accuracy	$\pm 3\%$ full scale ascending	$\pm 5\%$ full scale ascending
Scale ranges	0 ... 400 mbar to 0 ... 10 bar	0 ... 160 mbar to 0 ... 2.5 bar
Max. working pressure (static pressure)	Optionally 100, 250 or 400 bar	100 bar (scale ranges 0 ... 160 mbar and 0 ... 250 mbar: 50 bar)
Overpressure safety	Either side to maximum working pressure (exception for Model 700.02, scale ranges 0 ... 160 mbar und 0 ... 250 mbar: Overpressure safety up to 50 bar)	
Operating temperature		
Ambient	0 ... +60 °C	
Medium	+100 °C maximum	
Ingress protection	IP 54 (EN 60 529 / IEC 529)	
Pressure chamber with connections (exposed to pressure medium)	Stainless steel 1.4571, 2 x G 1/4 female, entry on the right and left, in-line (EN 837-1 / 7.3)	
Pressure element (exposed to pressure medium)	Compression spring, stainless steel 1.4310	
Magnetic piston (exposed to pressure medium)	Piston: stainless steel 1.4571, magnet: hard ferrite	
Separation diaphragm (exposed to pressure medium)	-	NBR
Dial	White aluminium with dual scale: outer scale black (bar), inner red (psi)	
Pointer	Black aluminium	
Case of indication	Black aluminium, die-casting	
Window	Acryl plastic, snap-fit window	

Optional extras

- Other threaded pressure connection female or male
- Bottom or back pressure entry, \oplus connection left
- Fine strainer integrated in \oplus connection
- Resettable max. drag pointer

Following accessories may be retrofitted locally:

- Reed contacts, single or double change over contact, adjustable from the outside
- Panel mounting flange (only for Model 700.01)
- Device for surface mounting

Dimensions in mm

Standard version Model 700.01

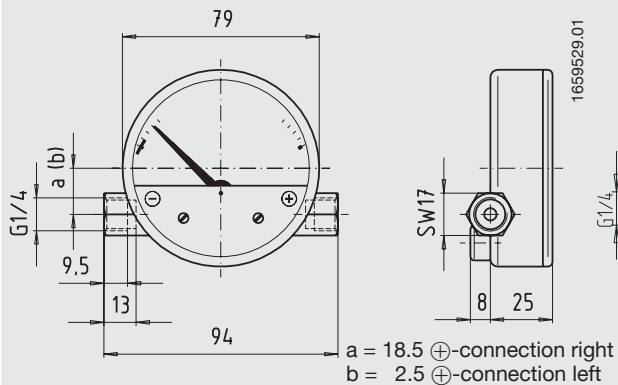

Standard version Model 700.02

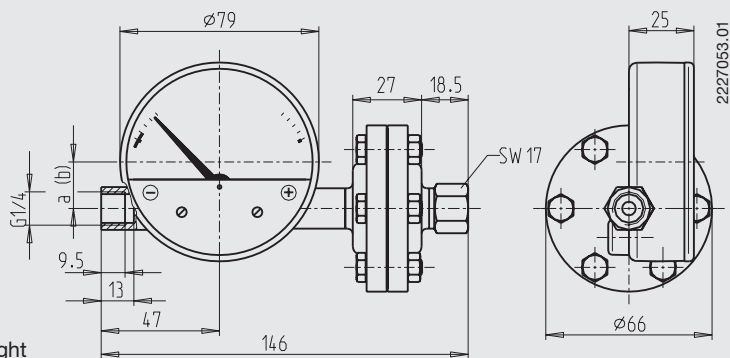

Optional version
Panel mounting flange (only Model 700.01)

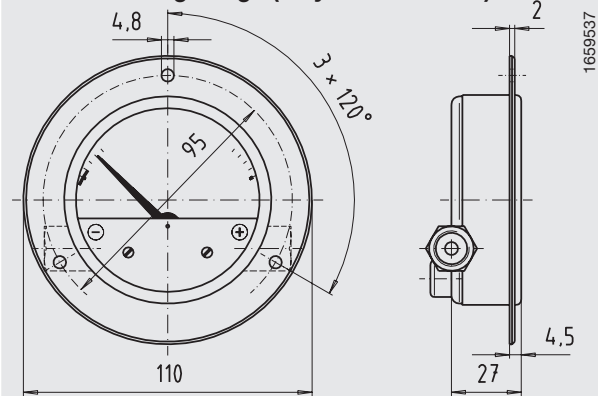

Optional version Reed contacts (single and/or double change over contact)
Model 700.01

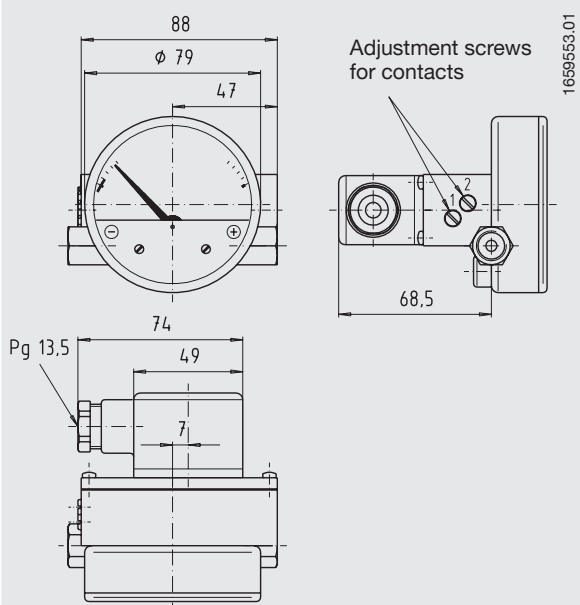

Model 700.02

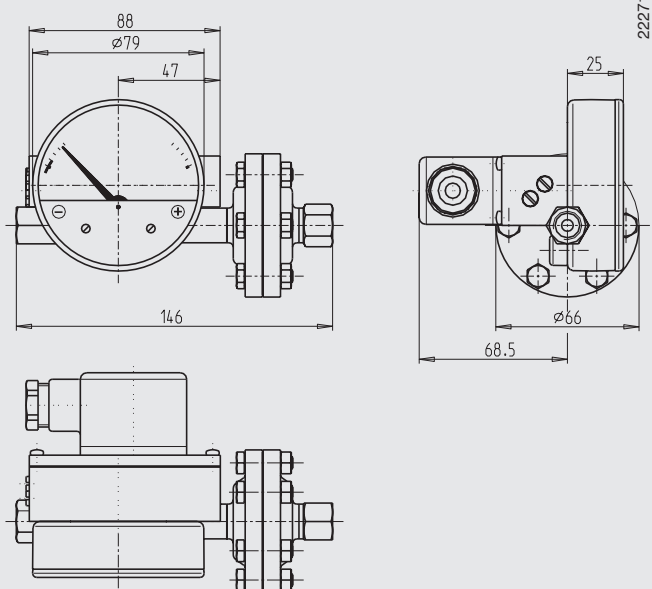

Electric wiring diagram and technical data Reed contact model 851.3 or 851.33:

Especially conceived to allow low current circuits to be switched directly, switch point may be set by means of adjusting screws from the exterior in a range of 10 ... 100 % of full scale value.

Max. switching voltage:	250 VDC / VAC	30 VDC / VAC
Max. load:	60 W	3 W
Max. strength of current:	1 A	0.2 A
Switching hysteresis:	5 % of full scale value	

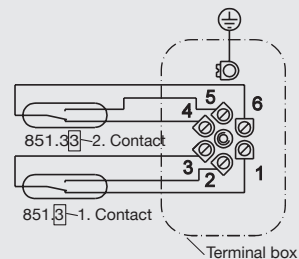

Ordering information

Model / Range / Scale / Process connection / Connector position / Overpressure safety (working pressure max.) / Options