

2300 Series

Bar Stock Metering Valves



Typical Applications

- Metering liquids and gases on analytical equipment
- Laboratory sampling
- Gas chromatography, analyzers
- Flow meters and gauges

Technical Data

BODY*	316 stainless steel, brass
MAXIMUM OPERATING PRESSURE	<i>Brass</i> <ul style="list-style-type: none">• 3000 psig up to 200° F (207 bar @ 93° C) <i>316 stainless steel</i> <ul style="list-style-type: none">• 3000 psig 100° F (207 bar @ 38° C)• 1000 psig 250° F (68.9 bar @ 121° C)
OPERATING TEMPERATURE RANGE	<i>Buna N O-ring Packing</i> <ul style="list-style-type: none">• -40° to 200° F (-40° to 93° C) <i>Teflon® Packing</i> <ul style="list-style-type: none">• -60° to 250° F (-51° to 121° C)
ORIFICE	.062", .125" (1.59 mm, 3.17 mm)
CV FACTOR**	1° stem, 0.062" orifice: 0.012 8° stem, 0.062" orifice: 0.086 8° stem, 0.125" orifice: 0.30

* Consult factory for other materials

** Cv factors shown are based on flow through entire metering range, approximately 20 handle turns

Features & Benefits

- 20 turn stem displacement for fine metering
- Optional micrometer vernier handle provides visual control and repeatable stem settings.
- 2 orifice sizes 0.062" (1.59mm) and 0.125" (3.17mm) are available with standard 8° stem
- Spring loaded stem in all 316 stainless steel valves prevents galling and enlargement of the orifice.
- For ultra fine metering, a 1° spring loaded stem design is available for all valves with 0.062" (1.59mm) orifice. See flow curves for details.
- Panel mounting is standard on all valves
- Bonnet lock prevents accidental disengagement of bonnet.

metering valves

2300 Series

Materials of Construction

316 Stainless Steel Valves (Teflon® Packing)

	DESCRIPTION	MATERIAL
1	CAP NUT (10-24)	Zinc Alloy
2	HAND WHEEL*	Nylon
3	WASHER	Teflon®
4	PACKING	Teflon®
5	PACKING NUT	316 stainless
6	MOUNTING NUT	316 stainless
7	HOUSING	316 stainless
8	BODY	316 stainless
9	SPINDLE POINT	316 stainless
10	SEAT	PCTFE
11	SEAT HOLDER	316 stainless
12	BALL	316 stainless
13	COMPRESSION SPRING	316 stainless
14	STEM	316 stainless

* Optional micrometer handle - Aluminum

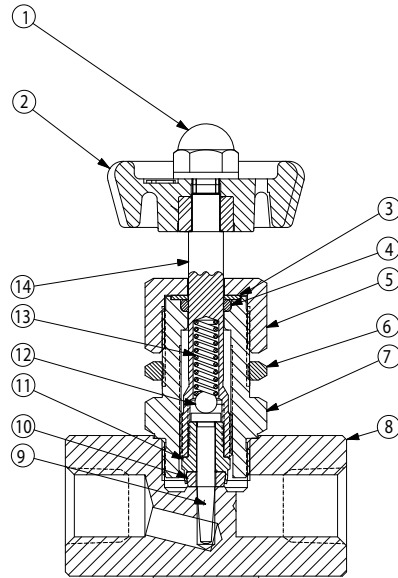

2335F[JY
stainless steel

Brass Valves (Buna-N Packing)

	DESCRIPTION	MATERIAL
1	CAP NUT (10-24)	Zinc Alloy
2	HAND WHEEL*	Nylon
3	STEM	316 stainless
4	WASHER	Nylon
5	O-RING	Nylon
6	PACKING NUT	Brass
7	MOUNTING NUT	FCB
8	HOUSING	Brass
9	BODY	Brass

* Optional micrometer handle - Aluminum

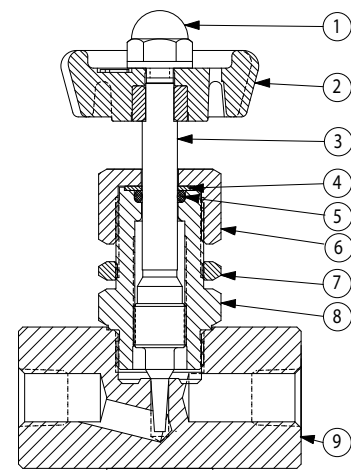

2331F[JB
Brass

Dimensions

FLOW PATTERN	A & B CONNECTIONS	PANEL MOUNTING DIMENSIONS									
			D	D'	E	F	F'	H	H'	PANEL THICKNESS	HOLE SIZE
GLOBE	1/4" NPT FEMALE	inch	3.59	3.88	2	1.41	1	0.5	0.75	0.13	0.64
		mm	91	98	51	36	25	12.7	19	3	16
	1/8" NPT FEMALE	inch	3.59	3.88	2	1.41	1	0.5	0.75	0.13	0.64
		mm	91	98	51	36	25	12.7	19	3	16
	1/4" LOK®	inch	3.59	3.88	2.63	1.41	1	0.5	0.75	0.13	0.64
		mm	91	98	67	36	25	12.7	19	3	16
ANGLE	1/4" NPT FEMALE	inch	3.75	4.06	1.44	1.41	1	0.56	0.81	0.13	0.64
		mm	95	103	37	36	25	14	21	3	16
	1/8" NPT FEMALE	inch	3.75	4.06	1.44	1.41	1	0.56	0.81	0.13	0.64
		mm	95	103	37	36	25	14	21	3	16

Dimensions for reference only, subject to change.

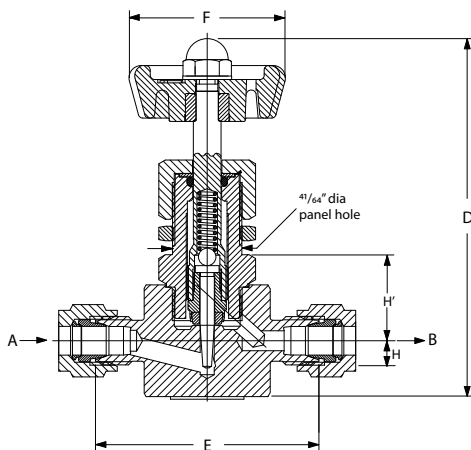

2335G[JY
316 stainless steel

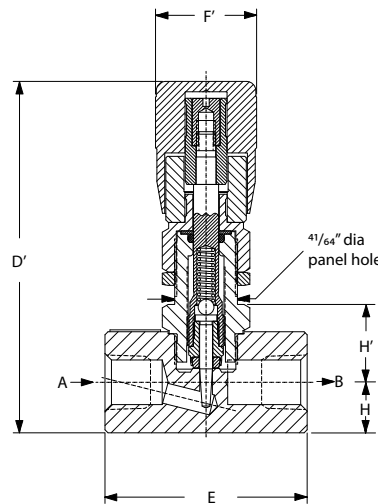

2335F4Y
316 stainless steel
(with optional micrometer handle)

2300 Series

Curves

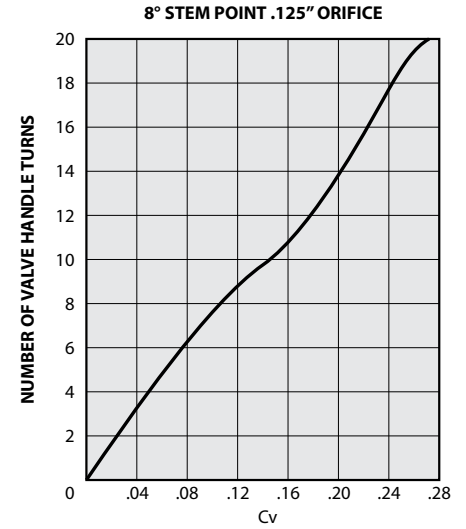
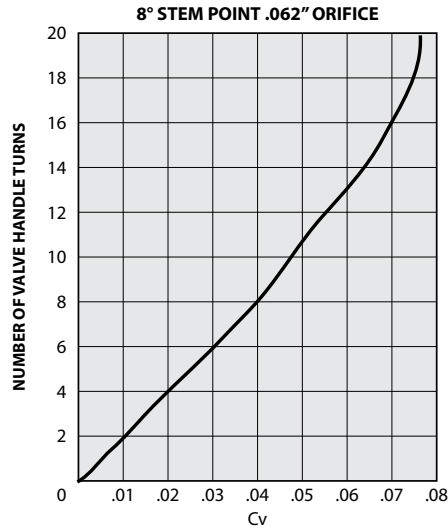
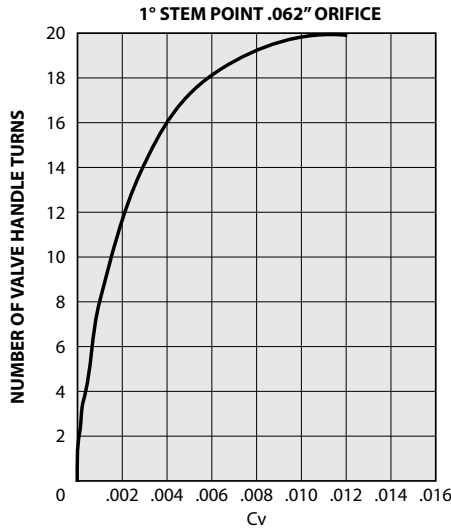

How to Order

FLOW PATTERN	CONNECTIONS	316 STAINLESS STEEL VALVES		BRASS VALVES	
		TEFLON® PACKING		BUNA-N O-RING PACKING	
		1° STEM SPRING LOADED	8° STEM SPRING LOADED	SOLID 8° STEM	SOLID 8° STEM
		.062" ORIFICE	.125" ORIFICE	.062" ORIFICE	.125" ORIFICE
GLOBE	1/8" NPT FEMALE	2355F2Y	2335F2Y	2311F2B	2331F2B
	1/4" NPT FEMALE	2355F4Y	2335F4Y	2311F4B	2331F4B
	1/4" LOK®	2355G4Y	2335G4Y	—	2331G4B
ANGLE	1/8" NPT FEMALE	—	—	2321F2B	2341F2B
	1/4" NPT FEMALE	—	—	2321F4B	2341F4B

Ordering Options

Spare Parts

Spare parts and repair kits are available for all needle valves. Please contact your distributor for specific information.

Cleaning and Testing

When ordering, please specify if oxygen cleaning or helium leak testing is required.

Additional Sizes

Additional sizes and options are available on special request. Please consult your local HOKE distributor.