

Bourdon tube pressure gauge Model 131.11, stainless steel version

WIKA data sheet PM 01.05



for further approvals
see page 2

Applications

- For gaseous and liquid aggressive media that are not highly viscous or crystallising, also in aggressive ambience
- CDA (clean dry air) applications
- Indication of failure alarm on gas cylinders
- Machine building and general plant construction

Special features

- All stainless steel construction
- Cost-effective and reliable
- Compatible with switch contacts (NS 50)
- Scale ranges up to 0 ... 1,000 bar



Bourdon tube pressure gauge model 131.11.50 with
2nd scale psi

Description

Design

EN 837-1

Nominal size in mm

40, 50, 63

Accuracy class

2.5

Scale ranges

NS 40 and 50: 0 ... 1 to 0 ... 600 bar

NS 63: 0 ... 1 to 0 ... 1,000 bar

or all other equivalent vacuum or combined pressure and vacuum ranges

Pressure limitation

Steady: 3/4 x full scale value

Fluctuating: 2/3 x full scale value

Short time: Full scale value

Permissible temperature

Ambient: -40 ... +60 °C

Medium: +100 °C maximum

Temperature effect

When the temperature of the measuring system deviates from the reference temperature (+20 °C):

max. $\pm 0.4 \%$ / 10 K of full scale value

Ingress protection

IP 54 per EN 60529 / IEC 60529

Standard version

Process connection

Stainless steel 1.4571,
lower mount (LM) or centre back mount (CBM)
G ¼ B (male), 14 mm flats

Pressure element

Stainless steel 316L
C-type or helical type

Movement

Stainless steel

Dial

Aluminium, white, black lettering, with pointer stop pin

Pointer

Aluminium, black

Case

Stainless steel

Window

Polycarbonate, snap-fitted in case

Options

- Other process connection
- Sealings (model 910.17, see data sheet AC 09.08)
- Assembly on diaphragm seals see product review diaphragm seals
- Slip-on bezel, stainless steel or polished stainless steel
- Window from instrument glass or laminated safety glass (both only in combination with slip-on bezel)
- Panel mounting flange, polished stainless steel (only for back mount connection)
- Surface mounting flange, stainless steel (NS 63)
- Triangular bezel, polished stainless steel, with clamp (only for back mount connection)
- Switch contacts (NS 50, data sheet SP 01.03)

Special versions

Gauges for ammonia plants (NS 63)

With temperature scale for refrigerant R 717 (NH₃) in °C,
scale ranges: -1 ... 0 ... 15 bar or -1 ... 0 ... 26 bar

CE conformity

Pressure equipment directive

97/23/EC, PS > 200 bar, module A, pressure accessory

Approvals

- **EAC**, import certificate, customs union Russia/Belarus/Kazakhstan
- **GOST**, metrology/measurement technology, Russia
- **KBA**, automotive, European Community
- **CRN**, safety (e.g. electr. safety, overpressure, ...), Canada

Certificates ¹⁾

- 2.2 test report per EN 10204 (e.g. state-of-the-art manufacturing, material proof, indication accuracy)
- 3.1 inspection certificate per EN 10204 (e.g. indication accuracy)

1) Option

Approvals and certificates, see website

Dimensions in mm

Standard version

Lower mount (LM)

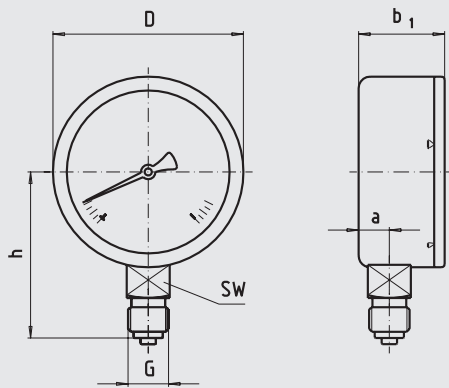

2184087.01

Centre back mount (CBM)

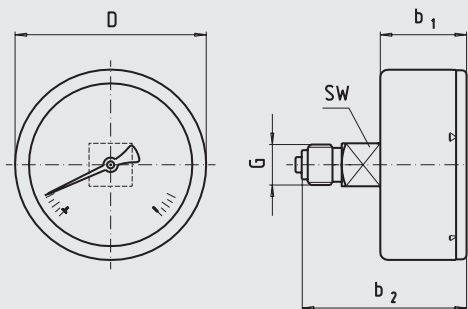

2184109.01

NS	Dimensions in mm						SW	Weight in kg
	a	b ₁ ±1	b ₂ ±1	D	G	h ±1		
40	9	28	52.5	39	G ¼ B	39	14	0.05
50	9.6	28	53.5	49	G ¼ B	47	14	0.09
63	10	28	53.5	62	G ¼ B	54	14	0.12

Process connection per EN 837-1 / 7.3